



**INSTRUCTION 77-9005**

**FLOWCONSOLE**

Part Number 77-7009  
Installation/Operation/Maintenance  
Rev. 3 - February 1991

World Headquarters  
621 Hunt Valley Circle, New Kensington, PA 15068  
Ph: 724-334-5000 • Fax: 724-334-5001 • Toll Free: 800-736-4666  
Website: [www.bacharach-inc.com](http://www.bacharach-inc.com) • E-mail: [help@bacharach-inc.com](mailto:help@bacharach-inc.com)

## WARRANTY

Bacharach, Inc. warrants to Buyer that at the time of delivery this Product will be free from defects in material and manufacture and will conform substantially to Bacharach Inc.'s applicable specifications. Bacharach's liability and Buyer's remedy under this warranty are limited to the repair or replacement, at Bacharach's option, of this Product or parts thereof returned to Seller at the factory of manufacture and shown to Bacharach Inc.'s reasonable satisfaction to have been defective; provided that written notice of the defect shall have been given by Buyer to Bacharach Inc. within one (1) year after the date of delivery of this Product by Bacharach, Inc.

Bacharach, Inc. warrants to Buyer that it will convey good title to this Product. Bacharach's liability and Buyer's remedy under this warranty of title are limited to the removal of any title defects or, at the election of Bacharach, to the replacement of this Product or parts thereof that are defective in title.

The warranty set forth in paragraph 1 does not apply to parts the Operating Instructions designate as having a limited shelf-life or as being expended in normal use.

THE FOREGOING WARRANTIES ARE EXCLUSIVE AND ARE GIVEN AND ACCEPTED IN LIEU OF (I) ANY AND ALL OTHER WARRANTIES, EXPRESS OR IMPLIED, INCLUDING WITHOUT LIMITATION THE IMPLIED WARRANTIES OF MERCHANTABILITY AND FITNESS FOR A PARTICULAR PURPOSE; AND (II) ANY OBLIGATION, LIABILITY, RIGHT, CLAIM OR REMEDY IN CONTRACT OR TORT, WHETHER OR NOT ARISING FROM BACHARACH'S NEGLIGENCE, ACTUAL OR IMPLIED. The remedies of the Buyer shall be limited to those provided herein to the exclusion of any and all other remedies including, without limitation incidental or consequential damages. No agreement varying or extending the foregoing warranties, remedies or this limitation will be binding upon Bacharach, Inc. unless in writing, signed by a duly authorized officer of Bacharach.

**NOTE:** *Hoses are considered consumable items and are excluded from the terms of this warranty.*

## TABLE OF CONTENTS

<b>SECTION</b>	<b>CONTENTS</b>	<b>PAGE</b>
<b>1.0</b>	<b>INTRODUCTION</b>	<b>1-1</b>
<b>2.0</b>	<b>INSTALLATION</b>	<b>2-1</b>
2.1	Unpacking	2-1
2.2	Compressed Air Requirement	2-1
<b>3.0</b>	<b>OPERATION</b>	<b>3-1</b>
3.1	Description of Controls and Instrumentation	3-1
3.1.1	Pneumatic System Controls	3-1
3.1.2	Calibration Fluid System Controls	3-2
3.1.3	Instrumentation	3-2
3.2	Principle of Operation	3-3
3.2.1	Calibration Fluid System	3-3
3.2.2	Pneumatic (Compressed Air) System	3-3
3.3	AFC System Checkout	3-4
3.4	ASA System Checkout	3-5
3.4	PT Pump Installation	3-5
3.5.1	Installation of Pump to Test Stand	3-5
3.5.2	Plumbing	3-5
3.5.3	Connecting PT Pump to Flowconsole	3-6
3.5.4	Connecting Flowconsole to Test Stand	3-6
3.5.5	Flow Control Circuit Selection	3-6
3.6	Reading the Flowmeter	3-7
<b>4.0</b>	<b>MAINTENANCE &amp; TROUBLESHOOTING</b>	<b>4-1</b>
<b>5.0</b>	<b>PARTS LIST &amp; DIAGRAMS</b>	<b>5-1</b>
5.1	Parts List, Flowconsole	5-1
5.2	Parts List, Accessory Group	5-2
5.3	Sales & Service Centers	5-2
5.4	Diagrams	5-2

**NOTES:**

## 1.0 INTRODUCTION

This instruction manual describes the Flowconsole and explains the purpose and operation of its major components. This manual gives information on a typical installation and hookup of the Cummins PT Pump between the Flowconsole and Bacharach Test Stand.

The Flowconsole Code 77-7009 is designed to test and calibrate Cummins PT Fuel Pumps when used in conjunction with a Bacharach Fuel Injection Pump Test Stand.

The Flowconsole is supplied with accessories which will enable the operator to perform recommended tests on Cummins PT Fuel Pumps. Several special adjustment tools are available from Cummins Engine Co.

A list of replacement parts, accessories, plus electrical and plumbing diagrams are included in the manual.

The Flowconsole enables the user to measure:

1. Fuel flow rate
2. Manifold pressure
3. Inlet vacuum
4. AFC performance
5. Gear pump pressure
6. ASA performance

**NOTES:**

## 2.0 INSTALLATION

### 2.1 Unpacking

The Flowconsole is mounted on a wooden pallet and boxed for shipment.

1. Unpacking Flowconsole
  - (a) Visually inspect the unit for indication of damage during shipment.

*Note:* If any damage is found, a claim should be made directly with the carrier.
  - (b) Remove the pallet bolts and lift the Flowconsole off the pallet.
  - (c) Inventory and inspect the accessories, checking them against Drawing No. 77-0070 (included with unit).

2. Flowconsole location

It is recommended that the Flowconsole be positioned to the side of the Test Stand that will make it more convenient for hookup.

### 2.2 Compressed Air Requirement (Figure 2-1)

1. Compressed air is required by the Flowconsole when testing PT Pumps which incorporate AFC (Air Fuel Control), ASA (Air Signal Attenuator) or are tested with Aneroids.

Required pressure range:

Minimum - 35 psi

Maximum - 90 psi

Air consumption: 0.3 SCFM (Approx.)

2. Customer supplied items:
  - (a) Quick-connect coupling
  - (b) Compressed air supply hose

Before connecting shop air line to filter make certain that control panel mounted High Pressure Regulator is turned fully counterclockwise (CCW) closed (Figure 3-1). Install a quick connect (1/4" NPT) and connect shop air pressure line to the filter which is mounted at the rear of the Flowconsole (Figure 2-1).

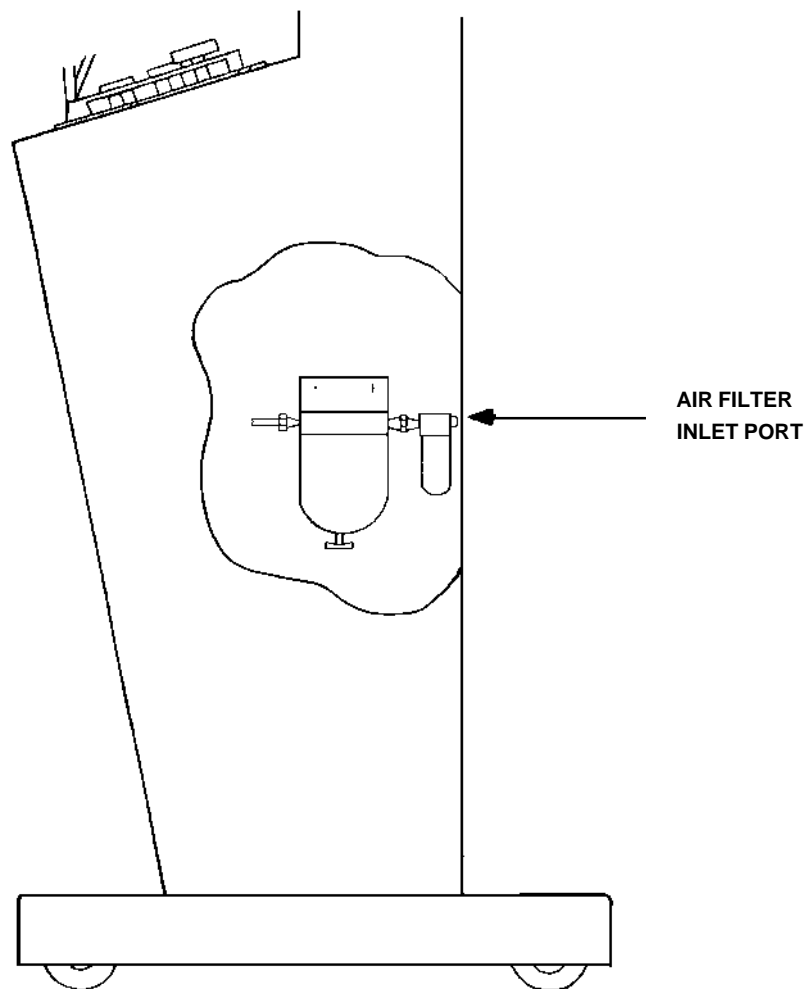

**Figure 2-1. Locating Air Filter Inlet Port (1/4" NPT)**

### 3.0 OPERATION

The Flowconsole includes the following systems and major components.

#### 3.1 Description of Controls and Instrumentation (Figures 3-1, 3-2)

The Flowconsole Panel contains precision gauges, flowmeters, controls, and necessary plumbing, all meeting the requirements of Cummins Engine Company. Located beneath the MANIFOLD PRESSURE, GEAR PUMP PRESSURE, and INLET VACUUM gages (Figure 3-2) are the needle valves which enable the operator to dampen out pressure pulsations.

The control panel (Figure 3-1) starting from right to left contains the High Pressure Regulator (AFC), Low Pressure Regulator (AFC), Air Selector Switch and Toggle Switch AFC/ASA. Located at the upper center of the control panel is the main Flow Control Valve, and in the center are selection controls for MAIN/IDLE flow operation. The hoses located at the base of the operator's console are identified on the panel.

##### 3.1.1 Pneumatic System Controls

1. High Pressure Regulator - regulates high pressure air required for operation of the fuel pump AFC.
2. Low Pressure Regulator - regulates low pressure air required for operation of the fuel pump AFC or ASA.
3. Air Selector Switch - applies preset low or high pressure air to the fuel pump AFC, ASA or exhausts pressurized air flow from the AFC.
4. Toggle Switch AFC/ASA - routes air flow to AFC or ASA.

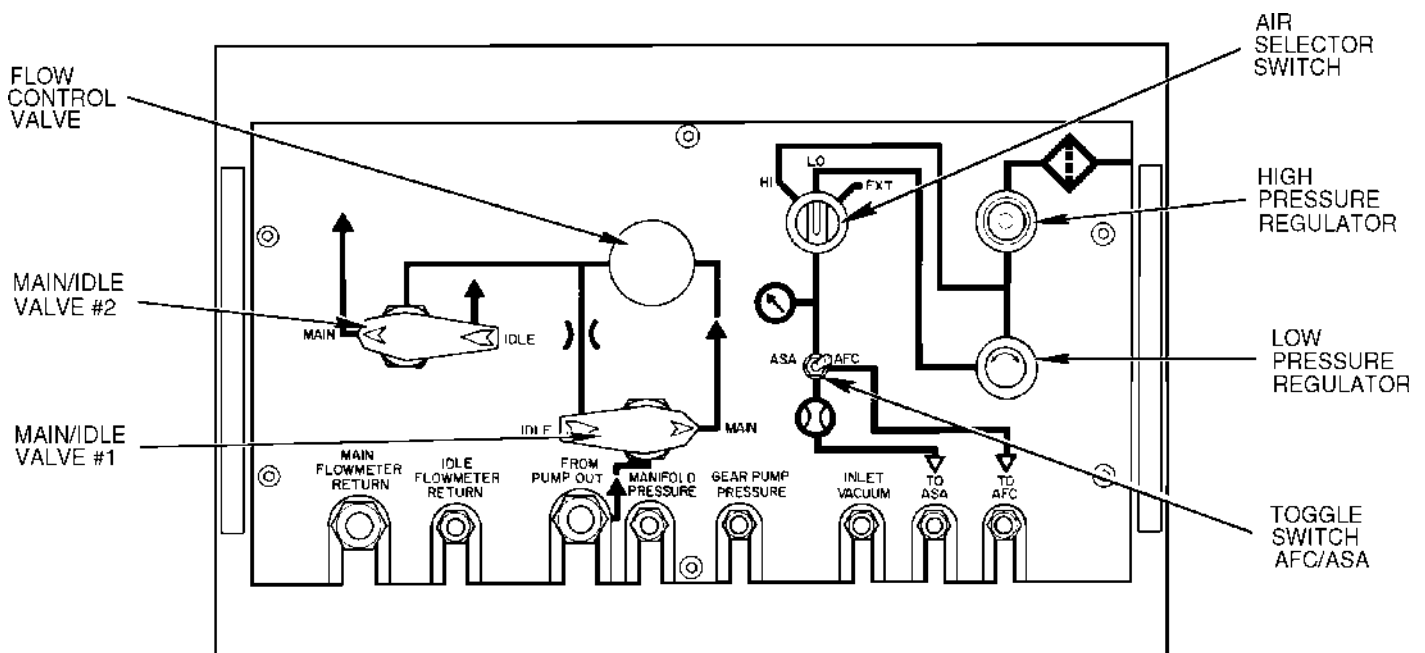

Figure 3-1. Identifying Controls

### 3.1.2 Calibration Fluid System Controls

1. MAIN/IDLE Valve #1 - routes fluid delivered from PT pump either to the Flow Control Valve or to the idle orifice in the circuit.
2. MAIN/IDLE Valve #2 - routes calibration fluid either to the MAIN FLOW-METER or the IDLE/THROTTLE LEAKAGE FLOWMETER.
3. Flow Control Valve - restricts the fluid flow from the pump to the flowmeters.

### 3.1.3 Instrumentation

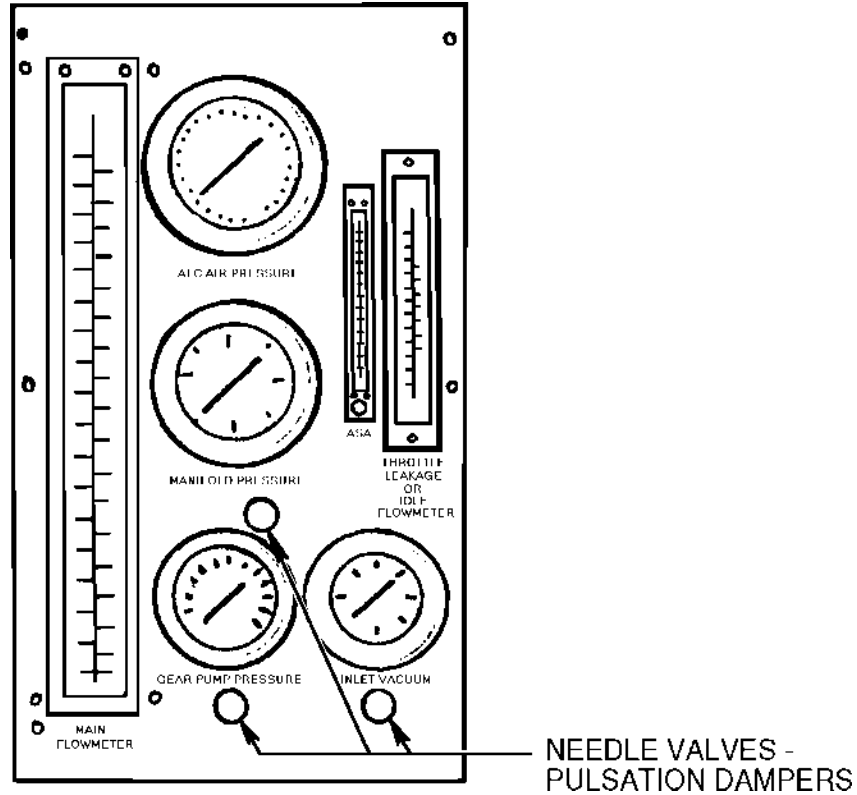

Figure 3-2. Identifying Needle Valves - Pulsation Dampers

Instrument	Range	Accuracy
MAIN FLOWMETER (Dual Scale)	60-400 PPH, 380-220 PPH	1/2% of reading
THROTTLE LEAKAGE OR IDLE FLOWMETER (Dual Scale)	10-50 cc/min, 50-500 cc/min	2% full scale
MANIFOLD PRESSURE gauge	0-300 psi	1/4% full scale
AFC AIR PRESSURE gauge	0-30 psi	1/4% full scale
GEAR PUMP PRESSURE gauge	0-600 psi	1/2% full scale
INLET VACUUM gauge	0-30" Hg.	1/2% full scale
ASA flowmeter	0-150	2% full scale

Table 3-1. Instrumentation (Figure 3-2)

### 3.2 Principle of Operation

#### 3.2.1 Calibration Fluid System (Figure 5-5)

The PT pump draws fluid from the test stand reservoir (at the CALIBRATION FLUID SUPPLY panel connection). The vacuum required by the pump supply line is achieved by first closing the BYPASS VALVE then partially closing the SHUTOFF VALVE on the side of the test stand. The shutoff valve of the 9000 stand is to be installed on the outside.

The fluid delivered by the pump is routed through a steel pipe and hose (FROM PUMP OUT) to the MAIN/IDLE Valve #1. At the same time a line is connected in “Tee” to the MANIFOLD PRESSURE gage on the panel. Depending on the position of MAIN/IDLE Valve #1 the fluid is routed either to the Flow Control Valve or to the idle orifice. By closing the Flow Control Valve fluid pressure is built up and indicated on the MANIFOLD PRESSURE gauge.

Downstream of the Flow Control Valve the fluid is routed to the MAIN/IDLE Valve #2. Depending on its position the fluid is routed either to the MAIN FLOWMETER or the THROTTLE LEAKAGE OR IDLE FLOWMETER. The fluid is then returned from either of these flowmeters back to the test stand reservoir (via the CALIBRATION FLUID RETURN panel connections).

When performing basic calibration of the pump the fluid is routed to the MAIN FLOWMETER via MAIN/IDLE Valve #1, Flow Control Valve and MAIN/IDLE Valve #2. When checking idle flow with the “psi method” fluid is routed through MAIN/IDLE Valve #1, through the orifice, and to the MAIN or THROTTLE LEAKAGE OR IDLE FLOWMETER. In this case pressure on the MANIFOLD PRESSURE is read and must conform to the specification. When checking the idle flow with the “cc method” fluid is routed through MAIN/IDLE Valve #1, MAIN/IDLE Valve #2 and to the THROTTLE LEAKAGE OR IDLE FLOWMETER.

#### 3.2.2 Pneumatic (Compressed Air) System (Figure 3-3 & 5-5)

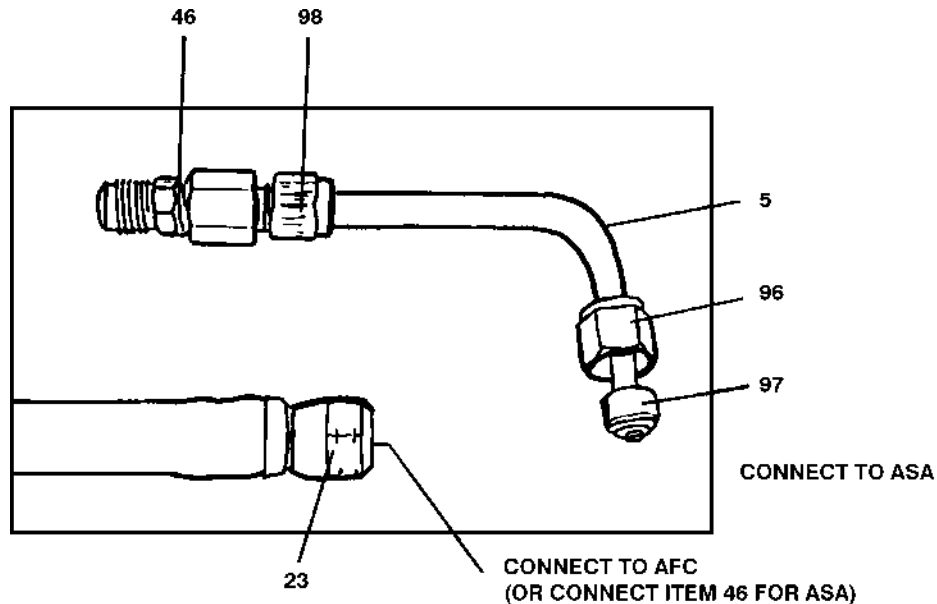

Figure 3-3. Identifying Plumbing Components Required for AFC and ASA Hook-up

Shop compressed air enters in the rear to a filter/water separator, then enters a second filter/water separator and is routed to the console mounted High Pressure Regulator.

**NOTE:** *It is imperative that the shop air is as free from moisture as possible.*

The High Pressure Regulator adjusts the pressure (maximum 30 psi is permitted because of the AFC gage) and supplies it to either the Low Pressure Regulator or the Air Selector Switch. If the Air Selector Switch is in HI position, air pressure is routed to the Toggle Switch AFC/ASA. If the Toggle Switch AFC/ASA is in ASA position the air is routed through the hose marked TO ASA. If the Toggle Switch AFC/ASA is in AFC position air is routed through the hose marked TO AFC. Note that the AFC gage is connected in the line between the Air Selector Switch and the Toggle Switch AFC/ASA. Air pressure supplied from the Low Pressure Regulator is also routed to the Air Selector Switch. When the Air Selector Switch is in LO position the low air pressure is admitted to the Toggle Switch AFC/ASA. The Air Selector Switch is turned to EXT when air pressure has to be exhausted from the AFC or ASA to the atmosphere.

Refer to Figure 3-3 (all items shown are part of the Flowconsole). The AFC/ASA Hose (item 23) is connected to copper Tube (item 5), Nut (item 96) and Sleeve (item 97) and is ready for ASA test hook-up. For AFC test, disconnect copper tube with fittings from the hose at the Male Connector (item 46). Then connect Hose (item 23) to AFC Inlet port using Male Connector (item 46).

The AFC port on the pump is 1/8" NPT. ASA has a fitting which will mate the 1/4" OD copper Tube (item 5), Rubber Seal (item 97) and Nut (item 96).

The "high" air pressure setting is generally 25 psi. The "low" pressure setting(s) are referenced in the Cummins PT pump test data. The air pressure(s) are applied to the AFC during PT pump calibration, as required.

### 3.3 AFC System Checkout (Figure 3-1)

1. Plug the AFC Hose Assembly.
2. Flip the Toggle Switch AFC/ASA to the AFC position. Set the Air Selector Valve to HI.
3. Lift-up the locking ring (red) on the High Pressure Regulator and set the air pressure to 25 PSI as indicated on the AFC AIR PRESSURE gauge.
4. Turn the Air Selector Valve to LO position and adjust the Low Pressure Regulator to 6 PSI AFC air pressure.

**NOTE:** *When a pump is installed refer to Cummins Shop Manual for the recommended AFC pressure.*

5. Switch the Air Selector Valve to HI and, if necessary, reset the air pressure to 25 PSI.
6. Position Air Selector Valve to "EXT" (exhaust) position to purge system to the atmosphere, the pressure must drop to "0".
7. Return the Air Selector Valve to HI.

### 3.4 ASA System Checkout

1. Set the Toggle Switch AFC/ASA to ASA, the Air Selector Switch to HI, and the Low Pressure Regulator to fully CCW (closed).
2. Plug the ASA hose, then set the High Pressure Regulator to read 29 psi on the AFC Air Pressure gauge.
3. With the ASA hose plugged, the ASA flowmeter should read zero (0). Any reading indicates an air leak down stream from the ASA flowmeter and ASA hose connections. No leakage is permitted.
4. With ASA hose unplugged, ASA flowmeter ball should rise rapidly to the top.

### 3.5 PT Pump Installation and Hookup (see Figure 5-1)

Use Figure 5-1 with this section to assist in the installation and hookup.

#### 3.5.1 Installation of Pump on Test Stand

1. Mount the Adapter Ring 67-0225 to the universal flange bracket and secure the pump to the adapter.
2. Attach tanged Drive Adapter 67-6998 to the front of the test stand flexible coupling using the three hex head capscrews, washers and lockwashers that were supplied with the test stand. This will “convert” the flexible coupling to a semirigid tanged coupling.

**NOTE:** *On Model 9000 stands, replace the flexible coupling with Cummins Drive Flange (77-0806) as described in Chapter 3 of the manual.*

3. Insert Coupling (Spider) 67-0222 or 77-0542 into the Drive Disk 67-0221 and attach them to the tanged drive.

**NOTE:** *Coupling (Spider) 67-0222 (black) is to be used when pump speeds are below 2100 rpm. Coupling (Spider) 77-0542 (white) is to be used when pump speeds are in excess of that speed.*

4. Slide the mounted pump, with the bracket, towards the spider. Engage and then secure the flange bracket to the bedplate (in case of a rail type stand secure bracket to the rails).
5. Connect the Throttle Spring 67-4199 between the screw on the side of the adapter ring and the pump throttle lever.

#### 3.5.2 Plumbing

1. On all Bacharach test stands except the 9000 stand use Hose Assembly 77-0373 and Manifold Assembly 77-0372 to connect pump inlet to the CALIBRATION FLUID SUPPLY connection on the front panel. The manifold assembly is connected to the pump inlet. The shutoff valve in these stands will be used to restrict flow and generate vacuum in the supply line.

**NOTE:** *On Model 9000 stands you must first install the 3/4" Ball Valve (supplied in the accessories with the test stand) to the DIRECT DRAW connection on the front panel.*

2. Another connection between the pump and the test stand is the cooling Hose Assembly (67-3787) that must be installed from the pump's top rear to the CALIBRATION FLUID RETURN connection on the front panel. If no connection is free, installation of a tee will be necessary. A spare male elbow is supplied in the Accessory Kit to install at the cooling connection, if required.

### 3.5.3 Connecting PT Pump to Flowconsole (plumbing)

Refer to Figure 5-1. Viewing the front of the console panel :

1. Connect hose FROM PUMP OUT and MANIFOLD PRESSURE, that ends with one steel tube, to pump outlet connection at the solenoid shutoff valve.
2. Connect hose GEAR PUMP PRESSURE to the bottom of the pump housing.

**NOTE:** *Gear pump pressure does not have to be measured in every test. Consult Shop Manual.*

3. Connect end of hose INLET VACUUM to the quick connect on the Manifold Assembly 77-0372.
4. Connect the hose AFC to the AFC connection on the pump (if installed).
5. Connect hose ASA to the ASA connection if installed, and when the test is required.

### 3.5.4 Connecting Flowconsole to Test Stand

1. Connect hose MAIN FLOWMETER RETURN to the CALIBRATION FLUID RETURN connection on the test stand front panel.
2. Connect hose IDLE FLOWMETER RETURN to another CALIBRATION FLUID RETURN connection on the test stand front panel.

**NOTE:** *On test stands that feature front panel quick connects it will be necessary to install several fittings and male quick connects to the above hoses before being able to make the connections. The male quick connects and necessary fittings were supplied with the accessories of the test stand(s).*

### 3.5.5 Flow Control Circuit Selection

Test Function	3-Way Valve #1 in Flow Diagram IDLE / MAIN	3-Way Valve #2 in Flow Diagram IDLE / MAIN	Control Valve Position
Check Main Flow	Main	Main	Adjust
*Check Throttle Leakage	Main	Idle	Open (Fully CCW)
Check Idle Flow	Idle	Idle	Out of Circuit

\* To check throttle leakage, be sure to move the fuel pump control lever to idle position before switching valve #2.

**Table 3-3. Valve Settings.**

### 3.6 Reading the Flowmeters (Figure 3-4)

The MAIN FLOWMETER indicates from 60-2200 pounds per hour (PPH) and the THROTTLE LEAKAGE OR IDLE FLOWMETER indicates from 10-600 cc/min.

When reading the MAIN FLOWMETER low range 60-380 PPH only, the smaller float in the tube will indicate the reading on the left side of the scale.

For high range Flowmeter indications 380-2200 PPH read the larger (bottom) float on the right side of the scale. The same method of reading applies to THROTTLE LEAKAGE OR IDLE FLOWMETER indications.

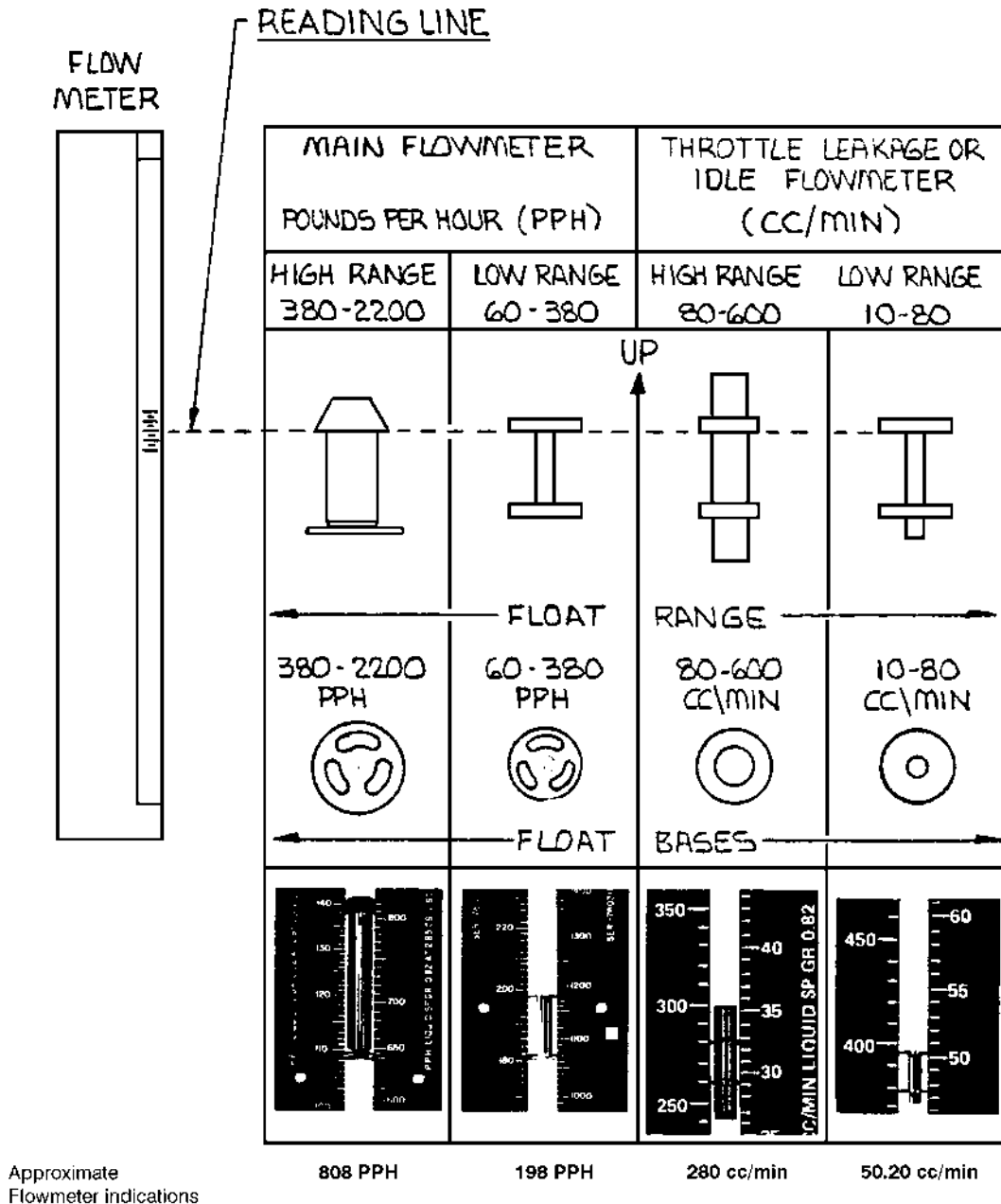

Approximate  
Flowmeter indications

For proper reading of Flowmeters, float(s) must be installed in the direction as shown.

Figure 3-4. Reading the Flowmeter

**NOTES:**

## 4.0 MAINTENANCE & TROUBLESHOOTING

1. The Flowconsole requires only periodic inspection/purging of the air filter and occasional cleaning of the Flowmeter. When required the Flowmeters may be cleaned as follows:
  - (a) Remove top and bottom clean out plugs.
  - (b) Remove the floats and float stops. Be careful not to damage the float. Floats are matched to the Glass Tube and cannot be replaced.
  - (c) Swab out the metering tube and end fittings with a suitable solvent such as naphtha or Trichlorethylene.
  - (d) Flush out the metering tubes with recommended calibrating oil.
  - (e) Reinstall floats, float stops and clean-out plugs.

**NOTE:** *If the flowmeters are suspected to be inaccurate, or are dropped during cleaning, they must be recalibrated at the factory.*

2. The idle orifice should be cleaned periodically. It can become clogged or contaminated and will give false results. When reinstalling the orifice, pay attention to the arrow (direction of flow) on the side of the hex.

**NOTES:**

## 5.0 PARTS LIST & DIAGRAMS

### 5.1 Parts List, Flowconsole

The following is a list of common replacement parts for the Flowconsole.

Item	Description	Part No.	Qty.
1	Hose Assy.	67-1035	1
2	Orifice	67-2395	1
5	Copper Tubing	77-0077	1
8	Gauge (300 PSI)	77-0001	1
9	Gauge (0 - 30" Hg)	77-0002	1
10	Gauge (0 - 30 PSI)	77-0003	1
11	Gauge (600 PSI)	77-0004	1
12	Flowmeter, Throttle Leakage or Idle Flowmeter	77-0007	1
13	Flowmeter, Main Flowmeter	77-0010	1
15	Fuel Discharge Connection Assy.	77-0047	1
20	Hose Assy. (From Pump Out)	77-0066	1
21	Hose Assy. (Main Flmtr. Ret.)	77-0067	1
22	Hose Assy. (Idle Flmtr. Ret.)	77-0068	1
23	Hose Assy. To AFC & To ASA)	77-0069	2
26	Flowmeter (ASA)	77-0076	1
46	Male Connector 1/8 MPT x 1/4 Tube	03-1534	2
49	Tubing, 3/8 Nylon	03-2912	AR
50	Tubing, 1/4 Nylon	03-2913	AR
54	Ball Valve, 3-way	03-4255	2
55	Needle Valve	03-4103	1
56	Needle Valve	03-4257	3
57	Regulator, High Pressure	03-4311	1
58	Regulator, Low pressure	03-4315	1
59	Tubing, Polyurethane (1/4 OD)	03-2920	AR
69	Hose	03-4900	AR
87	Filter, Full Flow	07-1586	1
88	Filter, Air	07-1583	1
90	Tubing, 3/8 Nylon (Tupe SN)	03-6356	AR
91	Valve, Selector Switch (Air)	104-0447	1
95	Tubing, 1/4" Nylon (Type SN)	03-6355	AR
96	Nut	03-2867	1
97	Sleeve	03-2868	1
102	Valve, 2-pos, 4-way	03-4265	1

## 5.2 Parts List, Accessories Group

The following is a list of parts in the Accessory Group (77-0070).

Item	Description	Part No.	Qty.
1	Coupling (White)	77-0542	1
2	Drive Disc	67-0221	1
3	Rubber Coupling (Black)	67-0222	1
4	Mounting Adapter	67-0225	1
5	Elbow, 1/8" NPT x 5/16" Tube	03-1586	1
6	Bushing, 1/4" x 1/8" NPT	03-0815	1
7	Hose Assembly	67-3787	1
8	Throttle Spring	67-4199	1
10	Male Conn. 1/8 MPT x 1/4 Tube	03-1534	2
11	Male Conn. 3/8 MPT x 5/8 Tube	03-1552	1
12	Male Elbow 90° 1/8 MPT x 1/4 Tube	03-1583	1
13	Male Conn. 1/8 MPT x 5/16 Tube	03-2820	1
15	Reducing Tee 3/8 x 3/8 x 1/4	03-1662	1
16	Swivel Connector 3/8 T	03-1689	1
18	Bracket Assembly	67-5180	1
19	Drive Adapter / Tanged	67-6998	1
20	Adapter Assembly	77-0371	1
21	Manifold Assembly	77-0372	1
22	Hose Assembly	77-0373	1
23	Adapter	03-2785	1
24	Adapter	03-2669	1
25	Adapter	03-2788	1
26	Two Valve AFC Calibration Kit	77-0541	1

## 5.3 Sales & Service Centers

### California

7281 Garden Grove Blvd.,  
Suite H  
Garden Grove, CA 92841  
Phone: 714-895-0050  
Fax: 714-895-7950  
E-mail: calservice@bacharach-inc.com

### New Jersey

7300 Industrial Park  
Rte. 130, Bldg. 22  
Pennsauken, NJ 08110  
Phone: 856-665-6176  
Fax: 856-665-6661  
E-mail: njservice@bacharach-inc.com

### Texas

5151 Mitchelldale, B-4  
Houston, TX 77092  
Phone: 713-683-8141  
Fax: 713-683-9437  
E-mail: txservice@bacharach-inc.com

### Indiana

8618 Louisiana Place  
Merrillville, IN 46410  
Phone: 219-736-6178  
Fax: 219-736-6269  
E-mail: indservice@bacharach-inc.com

### Pennsylvania

621 Hunt Valley Circle  
New Kensington, PA 15068  
Phone: 724-334-5051  
Fax: 724-334-5723  
E-mail: help@bacharach-inc.com

### Canada

Bacharach of Canada, Inc.  
151 Bentley Street Unit #6  
Markham, Ontario L3R 3X9 Canada  
Phone: 905-470-8985  
Fax: 905-470-8963  
E-mail: bachcan@idirect.com

## 5.4 Diagrams

The following pages contain diagrams for use in understanding and troubleshooting the Flowconsole.

(A list of parts for Figure 5-1 can be found on Sheet 2 of 2)

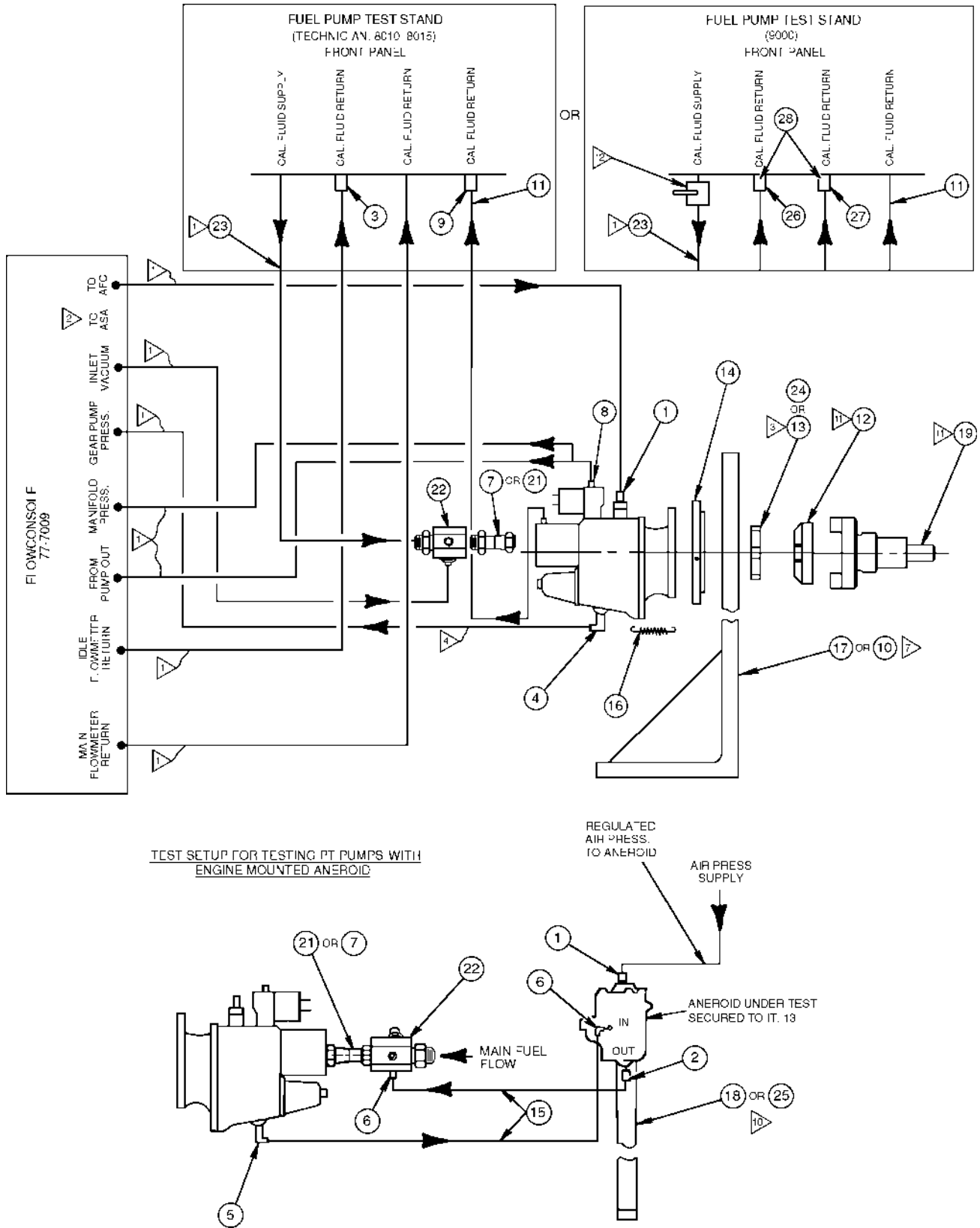
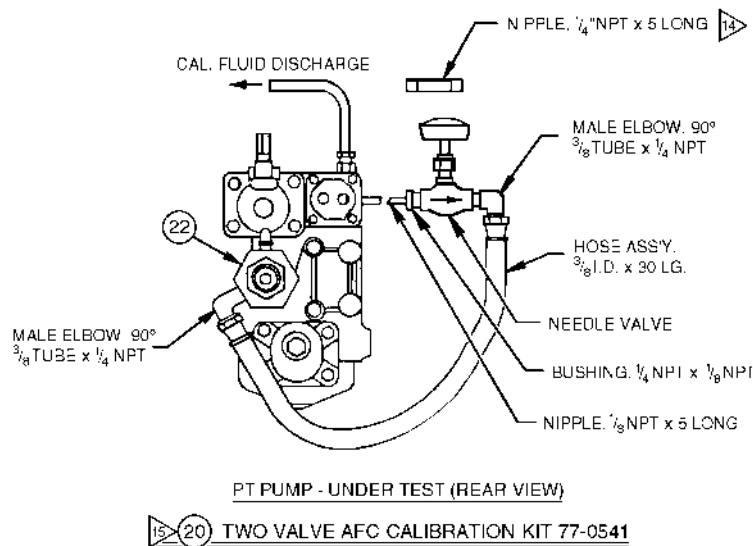

Figure 5-1. Pump Connection Diagram (1 of 2)

Derived from 77-9082DS1R2

Item	Description	Part No.	Notes:
1	Male Connector	03-1534	1 These hoses are part of Flowconsole 77-7009.
2	Male Connector	03-1539	2 This hose is used to check AFC or ASA leakage (Latest design pumps use hydraulic ASA).
3	Reducer	03-1725	3 For speeds over 2100 RPM (Approx.) use Coupling 77-0542 (white). Not Shown.
4	Male Elbow	03-1583	4 Gear pressure test is reqd. only in certain cases.
5	Male Elbow	03-1586	5 When Reqd. use two valve AFC Calibration Kit. Refer to Dwg. 77-0541 (Supplied).
6	Male Elbow	03-1587	6. For further details of testing pumps and use of special tools, refer to manufacturer's service instructions.
7	Adapter	03-2785	7 For rail type stands use item 10 (Not Shown).
8	Male Connector	03-2820	8 These items are part of Master Accessory Set supplied with current Bacharach test stands. All other items are part of Accessory Set 77-0070 supplied with the Flowconsole. Except as noted.
9	Reducer	03-1721	9 These items are part of Bracket Ass'y 67-5180 (Item 25).
10	Universal Flange Bracket	67-4125	10 For rail type stands use 67-5180 (Item 25).
11	Hose Assembly	67-3787	11 For 9000 FPTS item 12, 19 are not required. In their place use 77-0806 (supplied with the 9000).
12	Drive Disk	67-0221	12 This valve is supplied with the 9000 FPTS.
13	Coupling (Black)	67-0222	13 These items, supplied with the 9000 FPTS, are required to connect the two return hoses to the front panel.
14	Mounting Adapter Ass'y	67-0225	14 Use the 1/4 nipple in place of the bushing and 1/8 nipple as required.
15	Hose Assembly	67-1034	15 All components in this drawing are part of item 20.
16	Spring	67-4199	
17	Universal Flange Bracket	67-5387	
18	Throttle Arm Positioner	67-5649	
19	Drive Adapter	67-6998	
20	2 Valve AFC Cal. Kit	77-0541	
21	Adapter Ass'y	77-0371	
22	Manifold Ass'y	77-0372	
23	Hose Ass'y	77-0373	
24	Coupling (White)	77-0542	
25	Bracket Ass'y	67-5180	
26	Male Connector	03-1548	
27	Male Connector	03-1543	
28	Quick Connect	03-5382	



**Figure 5-1. Pump Connection Diagram (2 of 2)**

Derived from 77-9082DS1R2

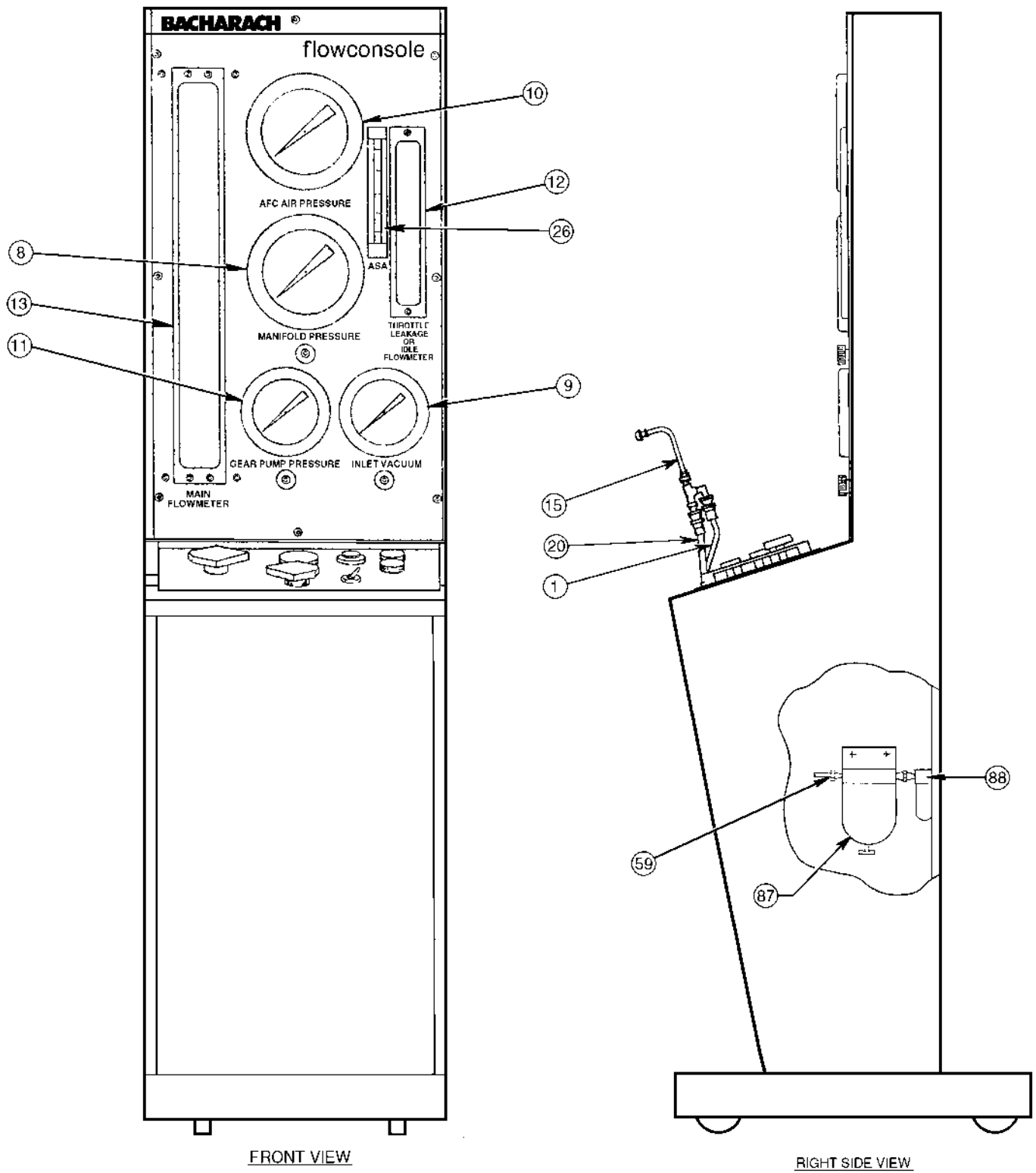
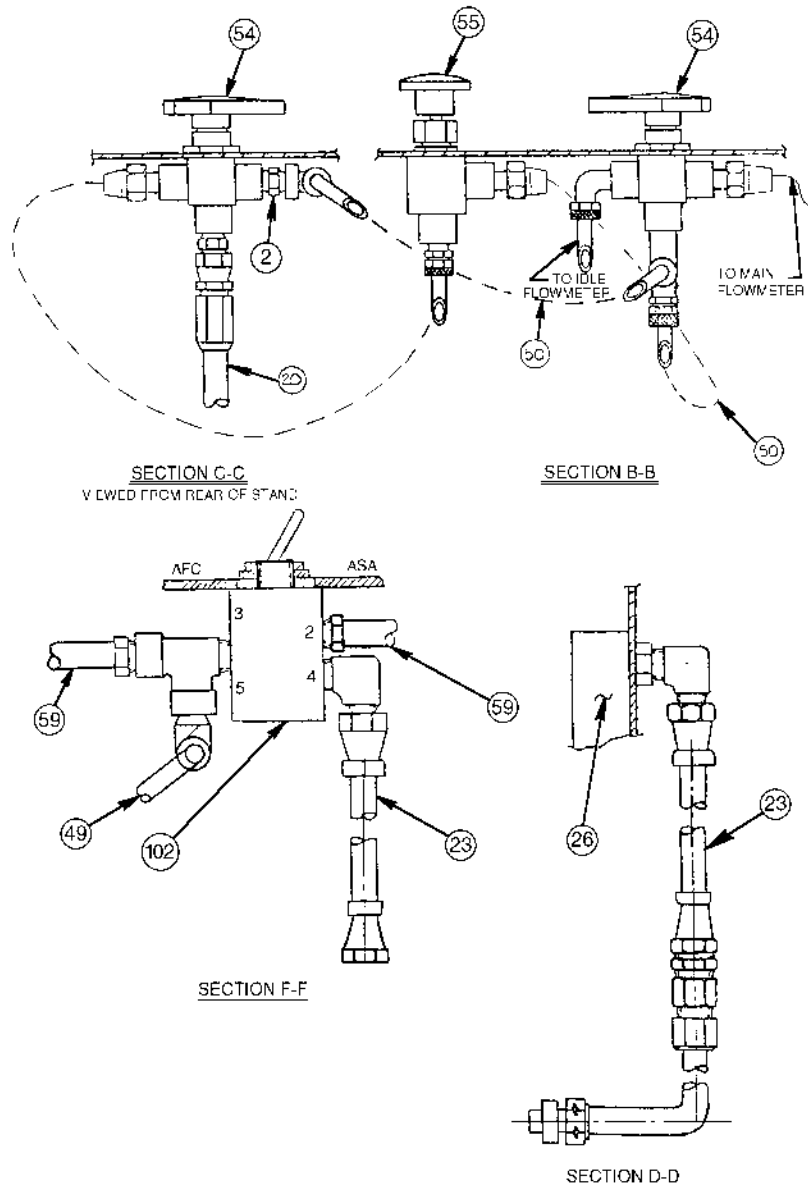
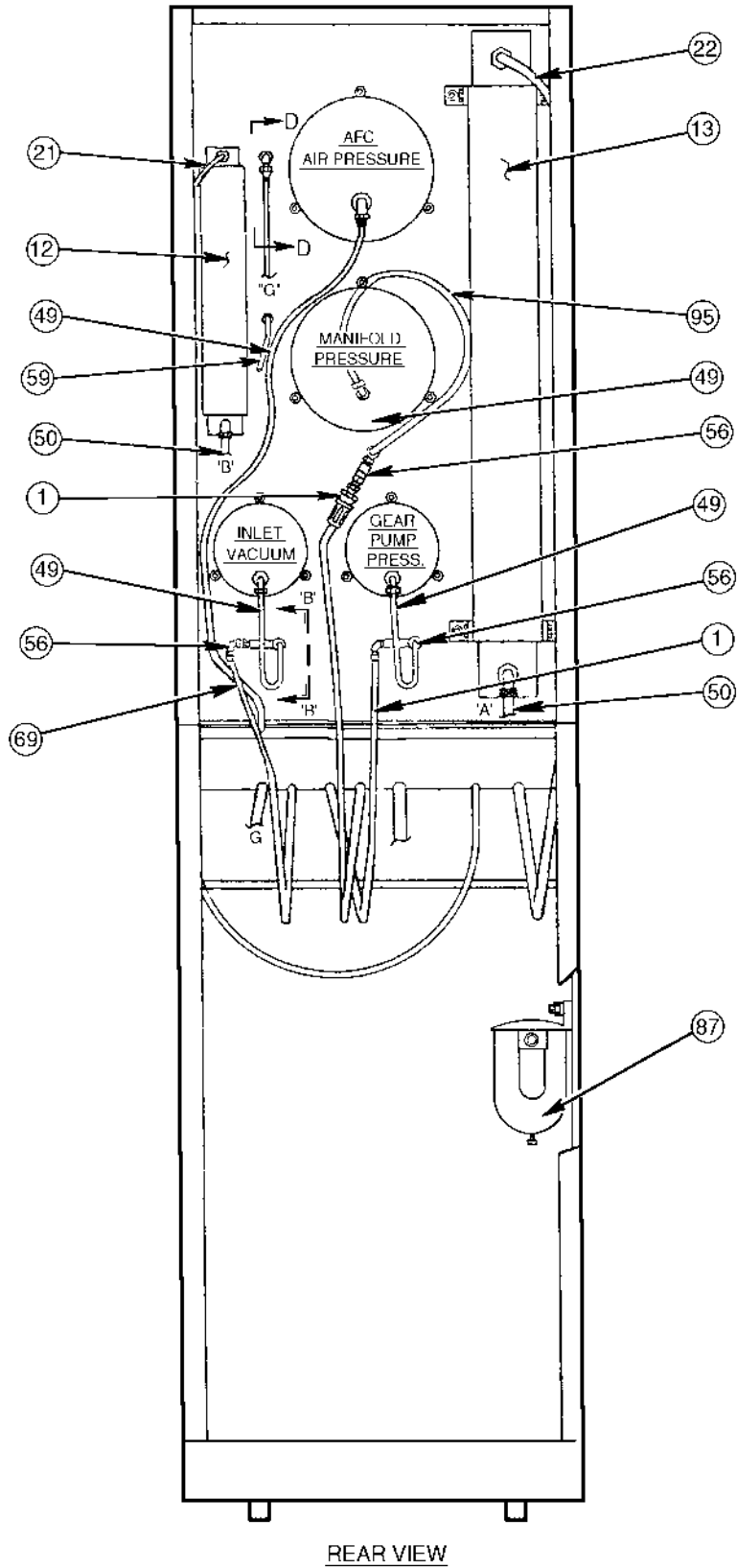

Figure 5-2. Front & Right Side View  
Derived from 77-7009DS2R38



**Figure 5-3. Sectional Views**  
Derived from 77-7009DS2R38



**Figure 5-4. Rear View**  
Derived from 77-7009DS2,3R38

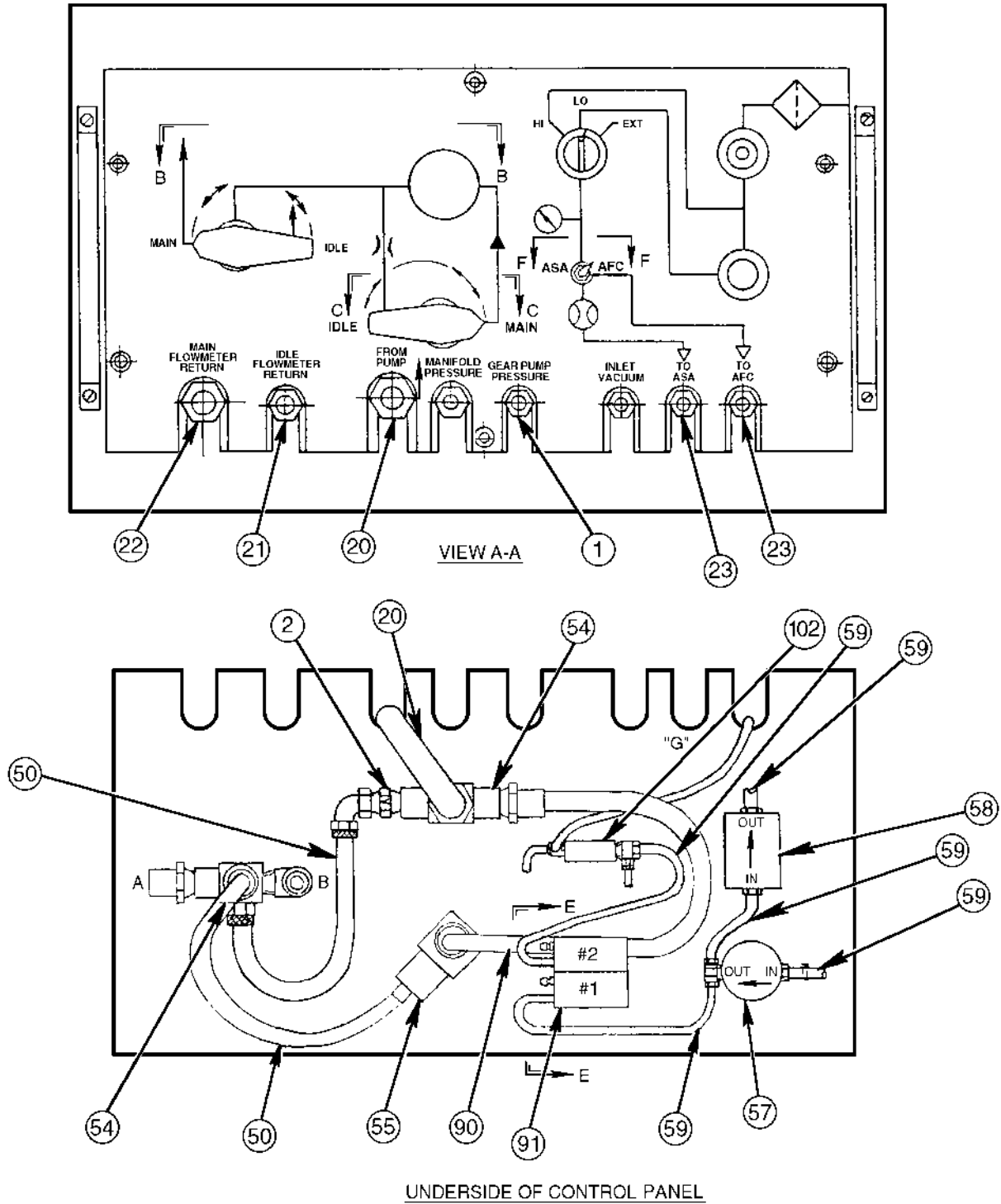

**Figure 5-5. Control Panel**  
Derived from 77-7009DS3R38

