



BACH-COM Plus Data Download Software

Part No. 19-3254

Instruction 19-9323

Installation/Operation

Rev. A – December 2001

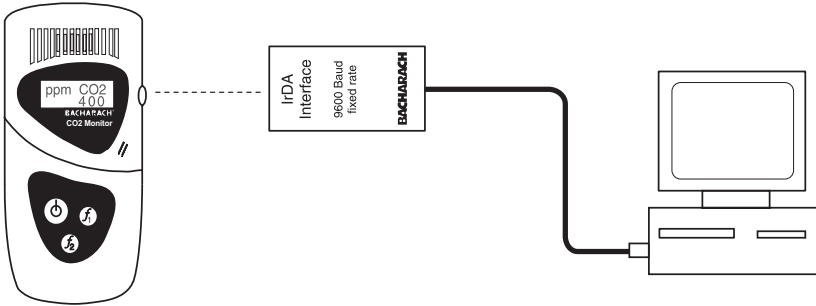

WARRANTY

Bacharach, Inc. warrants to Buyer that at the time of delivery this Product will be free from defects in material and manufacture and will conform substantially to Bacharach Inc.'s applicable specifications. Bacharach's liability and Buyer's remedy under this warranty are limited to the repair or replacement, at Bacharach's option, of this Product or parts thereof returned to Seller at the factory of manufacture and shown to Bacharach Inc.'s reasonable satisfaction to have been defective; provided that written notice of the defect shall have been given by Buyer to Bacharach Inc. within one (1) year after the date of delivery of this Product by Bacharach, Inc.

Bacharach, Inc. warrants to Buyer that it will convey good title to this Product. Bacharach's liability and Buyer's remedy under this warranty of title are limited to the removal of any title defects or, at the election of Bacharach, to the replacement of this Product or parts thereof that are defective in title.

THE FOREGOING WARRANTIES ARE EXCLUSIVE AND ARE GIVEN AND ACCEPTED IN LIEU OF (I) ANY AND ALL OTHER WARRANTIES, EXPRESS OR IMPLIED, INCLUDING WITHOUT LIMITATION THE IMPLIED WARRANTIES OF MERCHANTABILITY AND FITNESS FOR A PARTICULAR PURPOSE: AND (II) ANY OBLIGATION, LIABILITY, RIGHT, CLAIM OR REMEDY IN CONTRACT OR TORT, WHETHER OR NOT ARISING FROM BACHARACH'S NEGLIGENCE, ACTUAL OR IMPLIED. The remedies of the Buyer shall be limited to those provided herein to the exclusion of any and all other remedies including, without limitation incidental or consequential damages. No agreement varying or extending the foregoing warranties, remedies or this limitation will be binding upon Bacharach, Inc. unless in writing, signed by a duly authorized officer of Bacharach.

**Register Your Warranty by Visiting
www.bacharach-inc.com**

Notice:

Product improvements and enhancements are continuous, therefore the specifications and information contained in this document may change without notice.

Bacharach, Inc. shall not be liable for errors contained herein or for incidental or consequential damages in connection with the furnishing, performance, or use of this material.

No part of this document may be photocopied, reproduced, or translated to another language without the prior written consent of Bacharach, Inc.

Copyright © 2001, Bacharach, Inc., all rights reserved.

BACHARACH® is a registered trademark of Bacharach, Inc. All other trademarks, trade names, service marks and logos referenced herein belong to their respective owners.

Contents

1. Introduction	1
1.1 Features	1
1.2 System Requirements	1
1.3 Important Notes	1
1.4 Y2K Issues	2
2. Installation	3
2.1 IrDA Communication Device Installation	3
2.2 Software Installation	4
3. Operation	5
3.1 Starting BACH-COM Plus	5
3.2 Changing the COM Port Number	5
3.3 Testing and Establishing an IrDA Link	6
3.4 Main Screen Displays	6
3.4.1 Time and Date	7
3.4.2 Alarm Levels	7
3.4.3 Current Readings	8
3.4.4 Current Battery Status	8
3.4.5 Memory Display Area	8
3.5 Memory Download and Display	9
3.5.1 Downloading and Viewing Data	9
3.5.4 Saving Data	9
3.5.5 Monitor Memory	10
3.5.6 Clearing Memory	10
3.6 Configuring the Instrument	11
3.6.1 Logging Frequency	11
3.6.2 CO2 Channel (Comfort Chek 100 only)	11
3.7 Calibration	12
3.7.1 Remove CO2 Air Calibration Offset	12
3.7.2 CO2 Calibration	12
3.7.3 Cell 1 Calibration	14
3.7.4 Cell 2 Calibration	15
3.7.5 Return to Factory Calibration	16
3.8 About	16

NOTES:

1. Introduction

1.1 Features

BACH-COM Data Download Software is designed to allow communication between a personal computer (PC) and the Comfort Check 100/200, Model 2825/2830/2835 CO₂ Analyzer, and MGC 200 (hereafter referred to as the “instrument” in this manual).

Communications between the instrument and PC is achieved through an IrDA communication device, which is supplied as part of the BACH-COM Plus Software Package (Part No. 19-3254).

BACH-COM Plus provides a user the ability to:

- Change instrument parameters such as: the logging frequency, units of measurement, and alarm levels.
- Change an instrument’s calibration gas value, or change its current calibration.
- Download data from the instrument in a format that can be utilized by most spreadsheet programs.

1.2 System Requirements

- Windows® 9x/SE/Me/NT/2000/XP
- CD Drive
- 2 MB Hard Drive Space

1.3 Important Notes

After any of the instrument’s programming functions have been changed, the instrument must be turned off and then on for the new settings to take effect.

Do not use BACH-COM Plus to carry out any communications with the instrument while the instrument is being charged.

Some of the options available in BACH-COM Plus as described in this manual will vary with the type of instrument connected to the software (e.g., logging frequency, alarm configuration, user calibration functions).

1.4 Y2K Issues

When using BACH-COM Plus with Windows 98, ensure that the operating system has been updated to be year 2000 compliant; otherwise, BACH-COM may display and print year 2000 dates as 1996.

To check if your installed version of Windows 98 requires updating, use Microsoft's Windows Update feature to display a list of *critical updates* specific to your computer, or log onto www.microsoft.com and select the Downloads tab and choose Windows Update. If the file "Year 2000 Update 2" is listed, then your version of Windows 98 needs updated. If this file is not listed, then either the update has already been installed, or you are running a newer version of Windows.

2. Installation

2.1 IrDA Communication Device Installation

With the personal computer (PC) turned off, connect the IrDA communication device to the PC's COM1 serial communication port (it may be necessary to use a 9-pin to 25-pin adapter to make this connection).

COM1 is the default port used by the software. If COM1 is already in use by another device, then connect the IrDA device to the next available COM port. The software, however, will need to be reconfigured as described in Section 3.2 to use this port.

To ensure a good communications link, aim the IrDA communication device directly at the IrDA window on the side of the instrument. The optimum distance between the instrument and the IrDA device is 1–2 inches and on the same plane as shown in the figure below. This positioning can later be checked as described in Section 3.3.

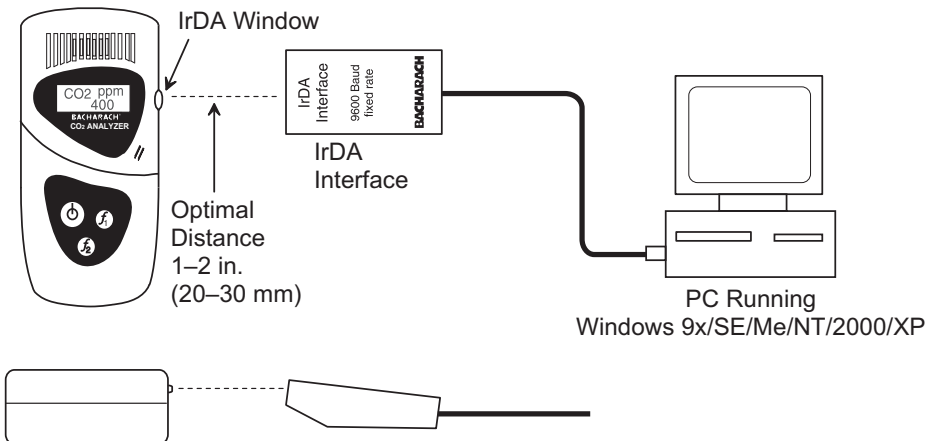

2.2 Software Installation

Important: Please read before installing. *If this software is being installed as an upgrade, then ensure that all previous versions have been **uninstalled** before proceeding.*

1. Start the PC; then insert the BACH-COM Plus CD into the PC's CD drive

Note: *Make sure that no other programs are running; otherwise, BACH-COM Plus will not install correctly if any shared files are in use.*

3. Type `D:\setup.exe` (where "D" corresponds to the drive letter of the CD drive) in the **Start | Run** dialog box; then click OK.
4. Follow the on-screen instructions to install the software.
5. After installation is complete, there will be a **Plus-COM** program icon in the **Start | Programs** listing.

3. Operation

3.1 Starting BACH-COM Plus

Start the BACH-COM Plus program by clicking the filename **Plus-COM** located in the **Start | Programs** list.

When the program is first started, its main screen is displayed. A typical screen for the Comfort Check 100 is shown in the figure below.

Note: *The information displayed varies with the type of instrument being used. Sections of the screen that are “grayed out” are functions or features that are not operational at this time.*

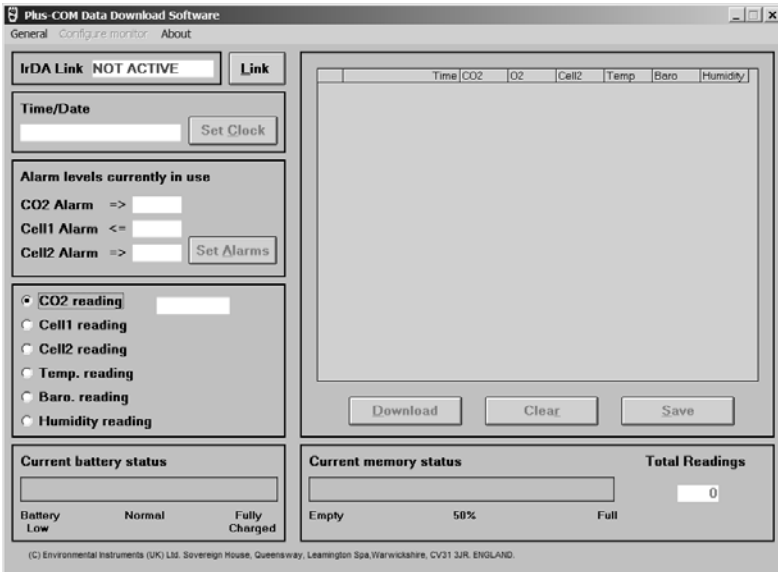

3.2 Changing the COM Port Number

If the IrDA device is connected to anything other than COM1, then the software must be reconfigured by choosing **Select comms port** under the **General** menu, and then selecting the appropriate port number. The program provides a warning if the chosen port is not available for use.

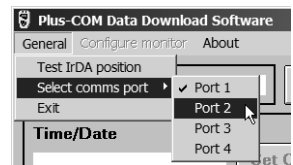

3.3 Testing and Establishing an IrDA Link

Ensure that the instrument and IrDA device are properly positioned as described in Section 2.1. Then establish an IrDA link as follows:

1. Under the **General** menu, click **Test IrDA Position**.

In the **IrDA Link** box, observe that if the instrument and IrDA device are misaligned or too far apart, then the message **Re-position** will appear. When the instrument and IrDA device are moved into alignment, the message **Position OK** appears.



2. Click the **Link** button. The **IrDA link** box will show the name of the instrument and also display the message **IrDA link established, please wait while initial setup data is transferred. (10 secs approx)**.
3. When the link is achieved the IrDA link box will then display **Active - ID XXXXX**, where the Xs refer to the instrument's serial number. The Active ID number will stay in the link box throughout the communication process.



Note: *If the IrDA link is disrupted, then the message **NOT ACTIVE** will appear in the **IrDA link** box. When this occurs, perform Steps 1 and 2 until the **Active** message reappears.*

3.4 Main Screen Displays

After a link has been established between the instrument and the IrDA device, the screen's six dialogue boxes show the following information relating specifically to the instrument linked to the PC. This information (except for memory) is updated every 10 seconds.

- IrDA link status
- Time and date currently set in instrument
- Alarm levels currently in use
- Reading of instrument
- Current battery status
- Memory status (when the Download button is clicked), including a listing of all stored readings, the total number of memory locations used, and the percentage of memory used

3.4.1 Time and Date

The **Time/Date** box shows the instrument's current time and date settings. Note that the date format is DD/MM/YY.

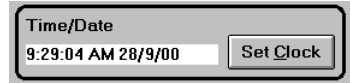

To change the instrument's time and date to match the PC's internal clock, click the **Set Clock** button – the following box is then displayed:

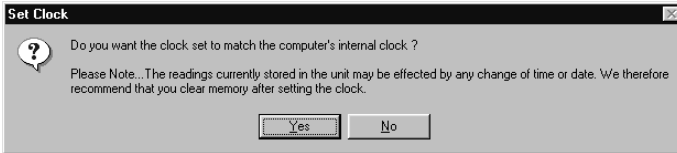

By clicking **Yes**, the time/date changes and the following message appears: **Clock Set to match the computer's internal clock**. To continue, click **OK** to return to the main screen.

Notes: *It is advisable to use the "Set Clock" option only when the instrument's memory is empty, as changing the time/date may affect the data currently stored in the instrument. It is also advisable to clear the memory after setting the clock.*

3.4.2 Alarm Levels

The **Alarm Levels currently in use** box shows the current alarm levels for all available active gas channels. In the example to the right, the CO₂ and O₂ channels are active for this instrument.

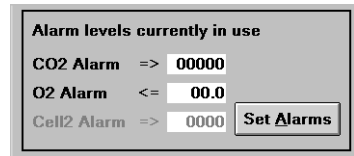

To change the alarm level(s), click the **Set Alarms** button – the **Set alarm levels** dialogue box is then displayed.

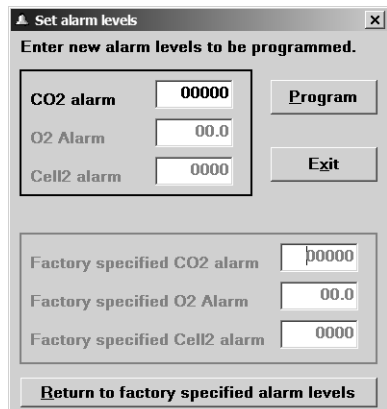

Change an alarm level by using the mouse to highlight the alarm level to be changed, and then typing in the desired level.

After setting the new alarm level(s), click the **Program** button to store these levels. The following message is then displayed: **Alarm levels programmed OK**. To continue, click **OK** to return to the main screen.

The **Factory Specified alarm** levels are also displayed in the **Set alarm levels** dialogue box. The instrument can be returned to these levels by clicking the **Return to factory specified alarm levels** button. The following message is then displayed: **Alarm levels returned to factory settings successfully**. To continue, click **OK** to return to the main screen.

3.4.3 Current Readings

Depending on the instrument being used, the readings dialogue box displays the instrument's current gas or environmental reading. In addition to CO₂, the O₂ and CO readings are displayed in the areas designated as "Cell1 reading" and "Cell2 reading," respectively. Choose the reading to be displayed by clicking its corresponding radio button.

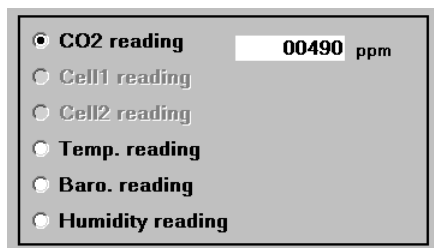

- **CO₂ reading** – expressed in “%” or “ppm” as determined by the instrument’s configuration
- **O₂ reading** – Oxygen expressed in %
- **CO reading** – Carbon Monoxide expressed in ppm
- **Temp. reading** – Temperature expressed in °F
- **Baro. reading** – Barometric pressure expressed in Hg
- **Humidity reading** – Relative humidity expressed in %

3.4.4 Current Battery Status

The **Current battery status** box shows a continuous real time display of the instrument’s approximate battery charge.

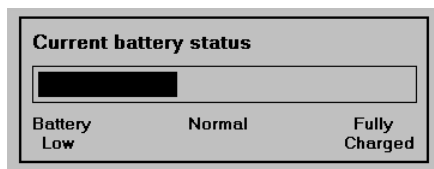

3.4.5 Memory Display Area

The data that is stored in the instrument is downloaded to the PC and displayed in the Memory dialogue box whenever the **Download** button is clicked. A complete description of the download process, and information on how to save and clear the data is provided in Section 3.5.

3.5 Memory Download and Display

3.5.1 Downloading and Viewing Data

Begin downloading data that is currently stored in the instrument's memory by clicking the **Download** button on the main screen. A progress bar will be displayed while the data is being transferred. Once the download is complete, the data will appear in an area to the right of the main screen as shown in the figure below.

If no data is stored, however, the message **No readings to download** will be displayed. Click **OK** to return to the main screen.

Time	CO2	O2	Cell2	Temp	Baro	Humidity
6/12/2001 11:47:30 AM	0490			75.9	28.82	33
6/12/2001 11:48:00 AM	1180			75.9	28.82	33
6/12/2001 11:48:30 AM	1340			75.9	28.82	33
6/12/2001 11:49:00 AM	0760			76.1	28.82	33
6/12/2001 11:49:30 AM	0570			75.9	28.82	33
6/12/2001 11:50:00 AM	0510			75.9	28.82	33
6/12/2001 11:50:30 AM	0510			75.9	28.82	33
6/12/2001 11:51:00 AM	0510			75.9	28.82	33
6/12/2001 11:51:30 AM	0510			75.7	28.82	33
6/12/2001 11:52:00 AM	0560			75.9	28.82	33
6/12/2001 11:52:30 AM	0500			75.7	28.82	33
6/12/2001 11:53:00 AM	0510			75.9	28.82	33
6/12/2001 11:53:30 AM	0530			75.7	28.82	33
6/12/2001 11:54:00 AM	0510			75.9	28.82	33
6/12/2001 11:54:30 AM	0500			75.7	28.82	33
6/12/2001 11:55:00 AM	0490			75.9	28.82	33
6/12/2001 11:55:30 AM	0490			75.7	28.82	33
6/12/2001 11:56:00 AM	0480			75.9	28.82	33
6/12/2001 11:56:30 AM	0580			76.1	28.82	33
6/12/2001 11:57:00 AM	0530			76.3	28.82	32
6/12/2001 11:57:30 AM	0530			76.6	28.82	32

3.5.4 Saving Data

Data that is downloaded is temporarily stored in the PC's memory. If a permanent file is required, click the **Save** button – the box to the right is then displayed:

Select target directory – The dialogue box in the center of the screen shows the current drive and directory selection. The drive may be changed by clicking on the arrow button and then choosing the desired drive from the pull-down menu. The

directory and any subdirectories may then be chosen by clicking on the available list in the top box. Observe that the chosen directory chain will appear in the **Enter data file prefix** box, along with a preselected file prefix. In this example the prefix is **CD98plus**.

Enter data file prefix – If desired, a unique prefix can be added to the filename. For example, a user’s name can be entered in place of CD98plus to identify the download of a particular instrument (e.g., JohnDoe).

Filename – When data is saved, a text file is created that contains the data in comma-separated-variable (CSV) format. For example, the filename automatically includes the prefix (optional), instrument’s ID number, file number, and date of storage (DD/MM/YY). For example, **JohnDoe_05030_35_041201.TXT** identifies a instrument belonging to John Doe, Instrument ID 05030, 35th file number, downloaded on 4, December, 2001.

After selecting the desired drive, directory and prefix, click the **Save** button to save the data record on the chosen drive.

Tip: *Changing the filename extension to “CSV” (comma separated variable) will allow the file to be directly opened in the spreadsheet program. For example, double clicking the filename JohnDoe_05030_35_041201.CSV in Windows Explorer will automatically start Microsoft Excel and load the file.*

3.5.5 Monitor Memory

The percentage of memory that is used is shown as a bar-gauge at the bottom of the data display. As memory is used, the bar will move toward its “Full” mark. Typically, 150 records can be stored, but this value varies depending on the number of parameters being measured by the instrument. When memory becomes full, no additional records are stored.

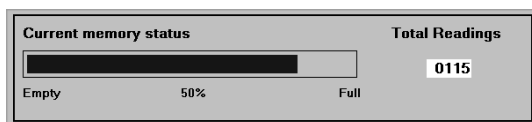

3.5.6 Clearing Memory

To clear memory, click the **Clear** button – the box shown to the right is then displayed. By clicking **Yes**, the instrument’s memory is cleared. To continue, click **OK** to return to the main screen.

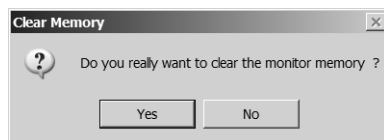

3.6 Configuring the Instrument

By clicking **Configure monitor** in the top menu bar, a dialogue box will appear that shows the functions or features of the instrument that can be altered, and the options available for selection. Select an option by clicking the radio button next to it. As an example, the figure below shows the configuration screen for the ComfortChek 100. Click **Program** to store the new configuration. The following message is then displayed: **New user configuration programmed OK**. To continue, click **OK** to return to the main screen.

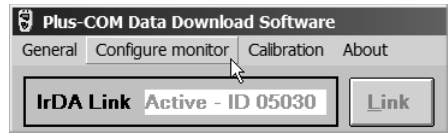

3.6.1 Logging Frequency

Determines how often the instrument logs gas readings to memory.

3.6.2 CO₂ Channel (Comfort Chek 100 only)

Configures the instrument to display the CO₂ level in either % or ppm.

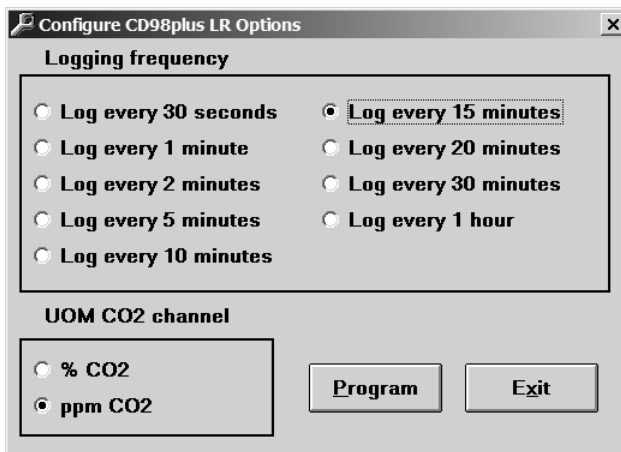

3.7 Calibration

Click **Calibration** in the top menu bar to display the calibration menu.

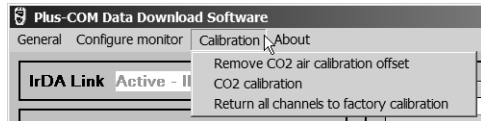

3.7.1 Remove CO2 Air Calibration Offset

To remove any CO₂ air calibration data, which was set by a user who performed either an air calibration or zero sensor procedure as described in the instrument's operation manual, select **Remove CO2 air calibration offset** from the **Calibration** drop down menu – the **Remove Air Cal. data** dialogue box will then appear. This box shows the instrument's current offset data.

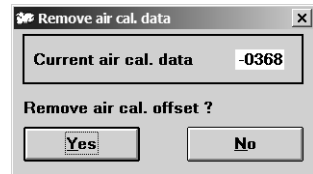

Click **Yes** to clear the data. The following message is then displayed: **User calibration data cleared OK**. To continue, click **OK** to return to the main screen.

3.7.2 CO2 Calibration

BACH-COM Plus can be used to change an instrument's calibration setting. This software offers the ability to set the calibration-gas value at the time of calibration.

Please note that performing this CO₂ calibration procedure will primarily improve accuracy in the range of the calibration gas used. This may cause *less* accurate readings of concentrations outside the newly calibrated range.

Important Information:

Please observe the following guidelines when calibrating the instrument.

- An air-calibration or zero-sensor calibration should NOT to be performed immediately after measuring a high concentration of gas.
- The calibration gas flow is not more than 120 cc/min.
- The instrument's gas exhaust port is not blocked, and there are no leaks in the tubing or connections.
- Do not allow the instrument to become pressurized with gas. Pressurization could lead to gas entering the instrument's case, in turn, causing erroneous readings.
- Calibration should be carried out in a properly ventilated area.
- Do not allow exhaust gases to build up in an enclosed area.

Calibration Equipment Required:

- Certified calibration gas cylinder (customer supplied):
 - 0.03 to 4.99% CO₂ for Low Reading Instruments
 - 30 to 50% CO₂ for High Reading Instruments
- Bacharach Calibration Kit 19-8027

Procedure:

1. Turn ON the instrument and leave it sample fresh air for at least 10 minutes to allow it to reach its working temperature (the pump, if part of the instrument, should be OFF).
2. Perform an air-calibration or zero-sensor calibration as described in the instrument's operation manual.
3. Start BACH-COM Plus and establish a communication link between the instrument and PC.
4. Connect the calibration equipment to the instrument's inlet connector per the figure below.
5. Select **CO₂ calibration** from the **Calibration** drop-down menu to display the **User Cal. gas value** dialogue box.

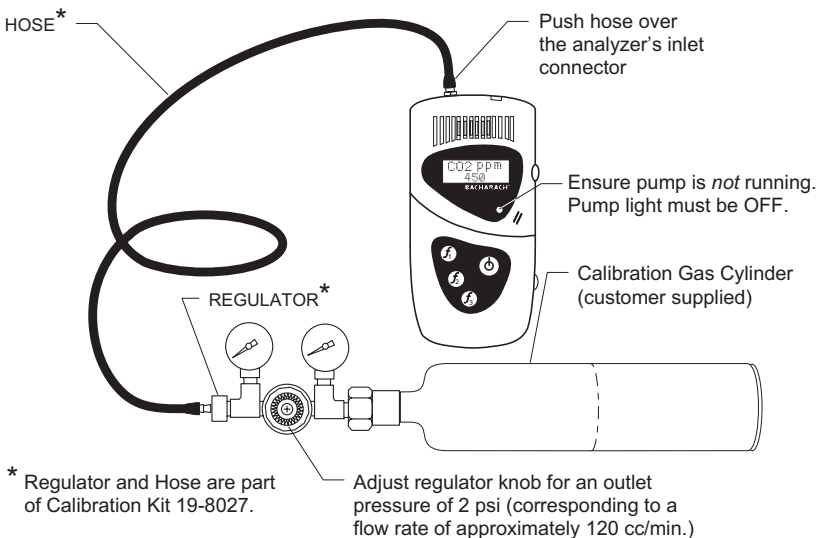
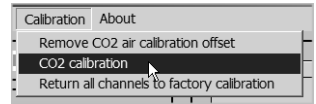

6. Open the gas regulator on the calibration equipment and allow gas to flow into the instrument.
7. Type into the dialogue box the **Calibration gas (%)** value that is stamped on the gas cylinder. In the example to the right, the calibration gas value is 0.5%.
8. Click the **Start** button to begin calibration. A bar at the bottom of the dialogue box will show the progression of the calibration process.
9. The calibration process will take approximately 1 minute; after which, the user will be prompted to apply the new calibration setting by clicking **YES**, or aborting the just completed calibration process by clicking **NO**.
10. For the new calibration to take effect, the instrument must be turned OFF and then ON.

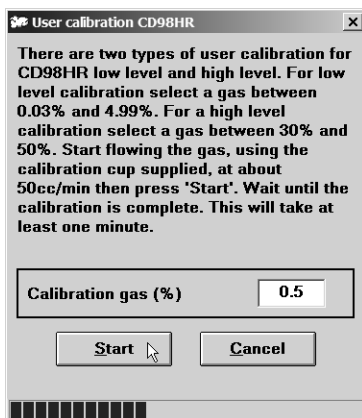

3.7.3 Cell 1 Calibration

If the instrument contains a sensor in cell position 1 (normally an Oxygen sensor), then the **Calibraton** drop-down menu will contain a listing for calibrating this sensor. Use this function to calculate a new span value that will adjust the reading displayed by the instrument.

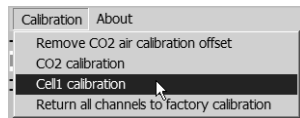

Calibration Equipment Required:

- Certified calibration gas cylinder containing the desired span gas concentration
- Bacharach Calibration Kit 19-8027

Procedure:

1. Turn ON the instrument and leave it sample fresh air for at least 10 minutes to allow it to reach its working temperature (the pump, if part of the instrument, should be OFF).

2. Start BACH-COM Plus and establish a communication link between the instrument and PC.
3. Connect the calibration equipment to the instrument's inlet connector per the figure shown on Page 13.
4. Select **Cell1 calibration** from the **Calibration** drop-down menu to display the **Change calibration data** dialogue box.
5. Open the gas regulator on the calibration equipment and allow gas to flow into the instrument.
6. Type into the dialogue box the **Target value** that is stamped on the gas cylinder.
7. Click **Calc** to calculate a new span gas value; then click **Program EEPROM** to reprogram the instrument to the new span gas value.
8. If successful, the message **All calibration data programmed OK** will appear. Click **OK** to dismiss this message and return to the main screen.
9. For the new calibration to take effect, the instrument must be turned OFF and then ON.

CELL1 calibration data.	
Current cell type	O2 %
Cell1 offset	65535
Cell1 span	0926
Current raw	2071
Target value	
Current reading	19.2

Program EEPROM Calc Exit

3.7.4 Cell 2 Calibration

If the instrument contains a sensor in cell position 2 (normally a Carbon Monoxide sensor), then the **Calibraton** drop-down menu will contain a listing for calibrating this sensor.

Calibrate the sensor in cell position 2 using the same equipment and procedure described in Section 3.7.3 *Cell 1 Calibration*, except apply a span gas and enter a target value that corresponds to the type of sensor installed in cell position 2.

3.7.5 Return to Factory Calibration

An instrument can be returned to its factory calibration setting by selecting **Return to factory calibration** from the **Calibration** drop down menu. To proceed, click the **Return to Factory Cal.** button. The following message is then displayed: **Return to factory settings successful. Please Note... Your instrument needs to be switched OFF/ON for the new settings to take effect.** To continue, click **OK** to return to the main screen.

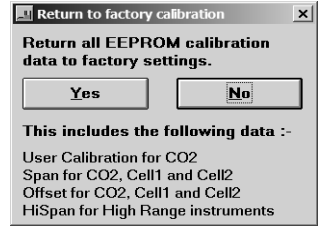
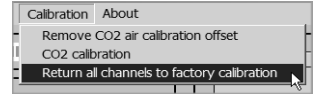

3.8 About

Selecting **About** from the top menu bar displays information about the software, including its version number and date of release. To continue, click **OK** to return to the main screen.





World Headquarters

621 Hunt Valley Circle, New Kensington, PA 15068

Ph: 724-334-5000 • Fax: 724-334-5001 • Toll Free: 800-736-4666

Website: www.bacharach-inc.com • E-mail: help@bacharach-inc.com